

# TriStar® VSTD

## EXPERT LINE



### EXCELLENCE AND PERFORMANCE

- **1,5 HP and 2 HP available**
- Smart inverter + Permanent Magnet Motor: **electricity saving up to 85%\***
- **Extremely quiet and reliable**
- **Optimised hydraulic design** for optimum efficiency
- **Remote control**, even through the smartphone, by connecting it to AquaRite® +
- **180° rotary box for convenient access** to the user interface
- **Union fittings provided**
- **Twist-Lock opening cover** for easy maintenance
- Recommended for pools **up to 120 m<sup>3</sup>\*\***
- **Replaces a single-speed TriStar®** without modifying the installation

\* Running at low speed. Electricity savings of 65% are generally achieved.  
 \*\* Running at low speed 24 hours

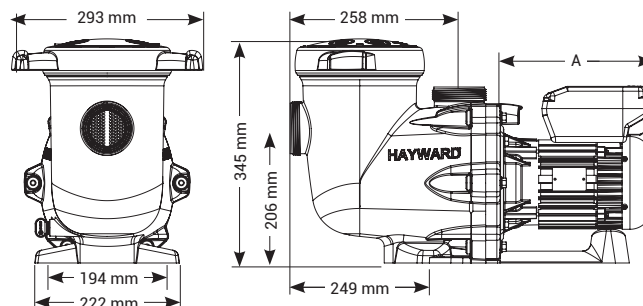

The intuitive control module displays relevant information such as real-time energy consumption. Improved control box, with the addition of five daily programs. "Skimming" function that allows the surface to be automatically skimmed every 1, 2 or 3 hours. **Timer Mode.**

### Technical Specifications

Max. water temp.	35°C
Mechanical seal	AISI 304, suitable for salt water
Motor-drive specifications	Class F, IP55, 50Hz, Brushless VFD
Housing/impeller/strainer/lid	PP+GF/Noryl® + GF/ABS/PC

### • 1.5 HP Curve

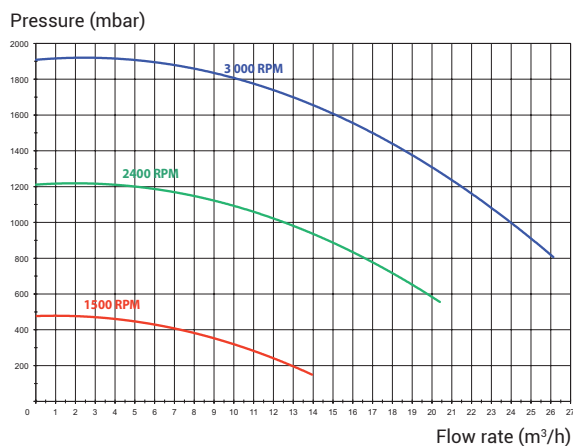

### • 2 HP Curve

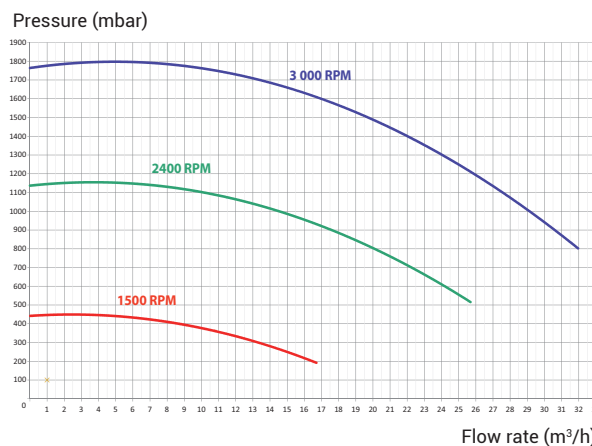

	Speed	Type	Dim. A	I/O	Flow rate*	Input Power P1	Output Power P2	Amperage*	Item
TRISTAR® VSTD	600 - 3000 RPM (20 rpm)	1.5 HP	230 mm	63 mm	@10 m : 24 m <sup>3</sup> /h @8 m : 26.3 m <sup>3</sup> /h	1240 W	1100 W	5.9 A	SP3216VSTD
	600 - 3000 RPM (20 rpm)	2 HP	250 mm	63 mm	@10 m : 28.8 m <sup>3</sup> /h @8 m : 31 m <sup>3</sup> /h	1500 W	1400 W	7.8 A	SP3220VSTD

\* at 3000 Rpm